

EAC



SGSCE

MD 2006/42/EC



ATEX 94/9/EC

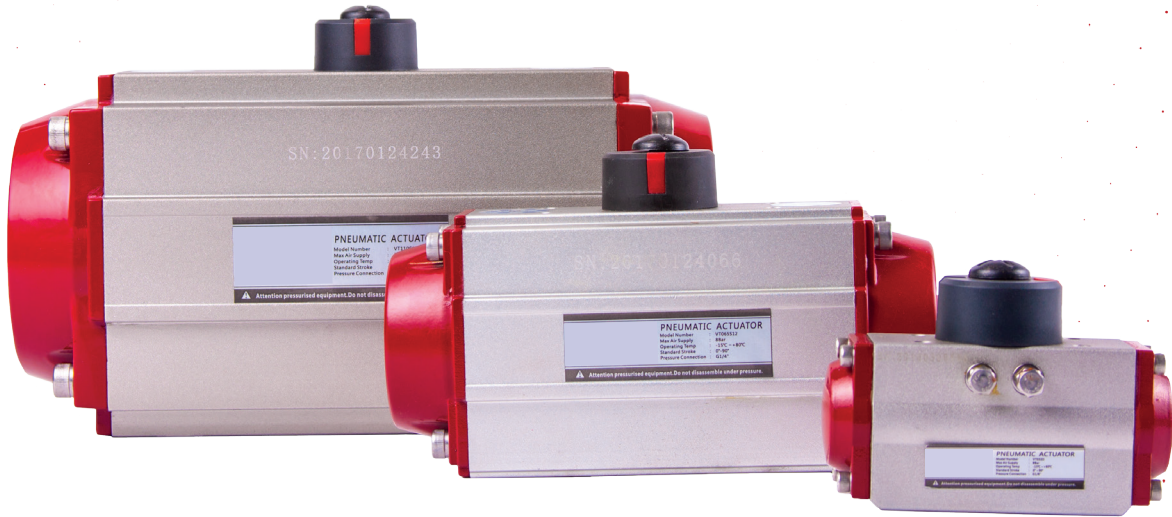

ACTUADOR NEUMÁTICO

Piezas y Materiales

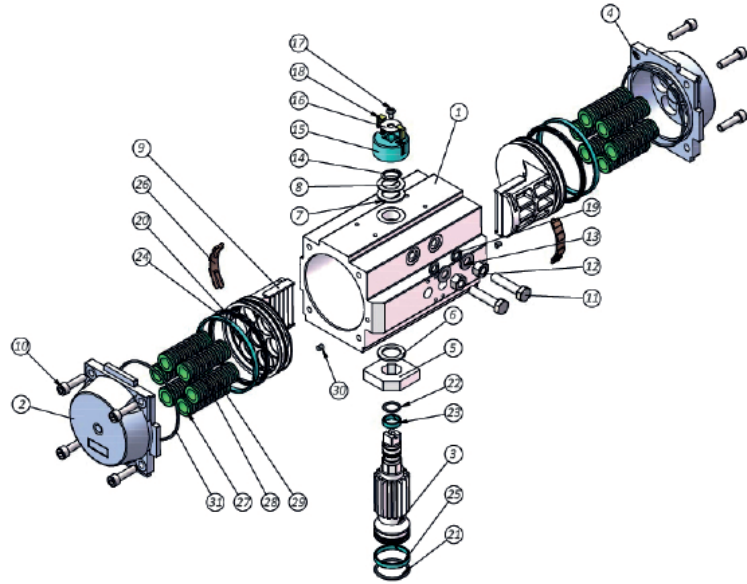

SGS



N° Parte	Descripción	Material	Cantidad	N° Parte	Descripción	Material	Cantidad	N° Parte	Descripción	Material	Cantidad
1	Cuerpo	Aleación de Aluminio	1	13	Arandela de tope	Acero Inoxidable	2	25	Buje Piñón Superior	POM +PTFE	1
2	Cubierta Izq.	Aleación de Aluminio	1	14	Clip de resorte	Acero	1	26	Banda de desgaste	Nylon	2
3	Eje de transmisión	Aleación de Acero	1	15	Indicador de posición	Nylon	1	27	Asiento del resorte	Nylon	24
4	Cubierta derecha	Aleación de Aluminio	1	16	Cojinete de empuje	Acero Inoxidable	1	28	Resorte	Acero Inoxidable	12
5	Cámara	Aleación de Acero	1	17	Tornillo de cabeza	Acero Inoxidable	1	29	Piñón	Tubo de Acero	12
6	Parte superior del piñón	POM +PTFE	1	18	Código de color	Nylon	2	30	Plug	NBR	2
7	O-ring	POM +PTFE	1	19	O-ring tornillo de ajuste	NBR	2	31	O-ring tapa	NBR	2
8	Arandela	Acero Inoxidable	1	20	O-ring Pistón	NBR	2				
9	Pistón	Aleación de Aluminio	2	21	O-ring Piñón inferior	NBR	1				
10	Tornillo tope tapa	Acero Inoxidable	8	22	O-ring Piñón	NBR	1				
11	Tornillo tope de carrera	Acero Inoxidable	2	23	O-ring Piñón superior	POM +PTFE	1				
12	Tuerca de ajuste	Acero Inoxidable	2	24	Buje Piñón Superior	POM +PTFE					

Modelo	VT032	VT050	VT065	VT075	VT085	VT095	VT110	VT125	VT140	VT160	VT190	VT210	VT240	VT270	VT300	VT350	VT400																	
Efecto	D S	D S	D S	D S	D S	D S	D S	D S	D S	D S	D S	S S	D S	D S	D S	D S																		
Diámetro (mm)	32	50	65	75	85	95	110	125	140	160	190	210	240	270	300	350	400																	
Volumen de aire Apertura (L)	0.03	0.09	0.19	0.30	0.44	0.88	0.83	1.41	1.76	2.85	4.75	6.60	11.40	15.80	19.09	27.65	42.81																	
Volumen de aire Cierre (L)	0.04	0.15	0.32	0.50	0.66	1.17	1.27	2.13	2.72	4.08	7.20	10.29	15.10	18.80	28.23	44.10	62.05																	
Tiempo de apertura (Seg)	0.3	0.3	0.9	0.4	0	0.4	0.9	0.9	1.0	0.9	1.4	0.9	1.4	1.3	2.4	1.3	2.8	2.0	4.8	2.2	2.4	2.9	3.4	3.2	3.8	4.4	5.0	5.0	6.0	6.2	7.4	7.5	9.6	
Tiempo de Cierre (C)	0.4	0.4	0.7	0.4	0.8	0.4	0.9	0.9	1.2	1.0	1.4	1.0	1.6	1.4	2.4	1.4	3.0	2.4	4.9	2.6	3.0	3.8	4.1	3.7	4.0	4.9	5.5	6.0	6.8	7.2	8.4	8.5	10.6	
Peso (Kg)	0.47	0.59	1.13	1.25	1.97	2.21	2.93	3.29	3.78	4.26	5.14	5.86	6.09	7.17	10.86	12.54	13.77	15.93	20.15	23.75	28.41	33.81	40.03	48.43	52.6	77.76	73.64	90.6	108	135.6	146.7	188.1	220.5	283.5

ACTUADOR NEUMÁTICO

Diagrama de Torque
Actuador doble acción



Diagrama de Torque
Actuador simple acción



Rangos de Torque - Actuador Doble Efecto en Nm										
Modelo	Suministro de Presión (Unidad Bar)									
	2.5	3	3.5	4	4.5	5	5.5	6	7	8
VT032	2.9	3.4	4.0	4.6	5.3	5.9	6.5	7.1	8.3	9.5
VT050	8.6	10.4	12.3	14.2	16.0	17.9	19.8	21.6	25.4	29.1
VT065	17.4	21.2	25.0	28.7	32.5	36.3	40.1	43.9	51.4	59.0
VT075	27.0	32.9	38.8	44.7	50.5	56.4	62.3	68.2	79.9	91.7
VT085	39.7	48.3	56.9	65.6	74.2	82.8	91.4	100.1	117.3	134.6
VT095	55.7	67.9	80.0	92.1	104.2	116.4	128.5	140.6	164.8	189.1
VT110	72.0	89.3	105.0	120.6	136.3	152.0	167.6	183.3	214.6	245.9
VT125	128.7	159.5	187.5	215.4	243.4	271.4	299.4	327.4	383.3	439.3
VT140	196	237	278	319	360	401	442	483	565	647
VT160	263.5	326.6	383.9	441.2	498.5	555.8	613.1	670.4	785.0	899.7
VT190	428.5	518.0	607.3	696.6	785.9	875.3	964.6	1053.9	1232.5	1411.1
VT210	598.2	723.2	847.9	972.6	1097.3	1222.0	1346.6	1471.3	1720.7	1970.1
VT240	928.3	1122.0	1315.0	1508.0	1702.0	1895.0	2089.0	2288.0	2669.0	3056.0
VT270	1305.0	1577.0	1849.0	2121.0	2393.0	2665.0	2837.0	3209.0	3753.0	4297.0
VT300	1678.6	2029.4	2379.3	2729.2	3079.1	3429.0	3789.9	4128.8	4528.5	5528.3
VT350	2492.5	3011.8	3531.1	4050.4	4569.6	5088.9	5608.2	6127.5	7166.0	8204.6
VT400	3798.1	4589.4	5380.7	6172.0	6963.3	7754.5	8545.8	9337.1	10919.7	12502.2

Rangos de Torque Actuador Simple Efecto en Nm																						
Modelo	Suministro de Presión (Unidad Bar)																					
	2.5		3		3.5		4		4.5		5		5.5		6		7		8		CARRE- RA DEL RESORTE	
	0°	90°	0°	90°	0°	90°	0°	90°	0°	90°	0°	90°	0°	90°	0°	90°	0°	90°	0°	90°	0°	
VT050S05	5.1	3.4	6.9	5.3	8.8	7.2	10.7	9.0	12.5	10.9	14.4	12.8	16.3	14.6	18.1	16.5	21.9	20.2	25.6	23.9	5.2	3.5
VT050S06	4.4	2.4	6.2	4.3	8.1	6.1	10.0	8.0	11.8	9.9	13.7	11.7	15.6	13.6	17.4	15.5	21.2	19.2	24.9	22.9	6.2	4.2
VT050S07			5.5	3.2	7.4	5.1	9.3	7.0	11.1	8.8	13.0	10.7	14.9	12.6	16.7	14.4	20.5	18.2	24.2	21.9	7.2	4.9
VT050S08					6.7	4.1	8.6	5.9	10.4	7.8	12.3	9.7	14.2	11.5	16.0	13.4	19.8	17.1	23.5	20.9	8.2	5.6
VT050S09						7.9	4.9	9.7	6.8	11.6	8.6	13.5	10.5	15.3	12.4	19.1	16.1	22.8	19.8	9.3	6.3	
VT050S10							9.0	5.7	10.9	7.6	12.8	9.5	14.6	11.3	18.4	15.1	22.1	18.8	10.3	7.0		
VT050S11									10.2	6.6	12.1	8.4	13.9	10.3	17.7	14.0	21.4	17.8	11.3	7.7		
VT050S12											11.4	7.4	13.2	9.3	17.0	13.0	20.7	16.7	12.4	8.4		
VT065S05	8.7	4.3	12.5	8.1	16.3	20.0	15.6	23.8	19.4	27.6	27.6	23.2	31.4	27.0	35.2	30.8	42.7	38.3	50.3	45.9	13.1	8.7
VT065S06	7.0	1.7	10.7	5.5	14.5	18.3	13.0	22.1	16.8	25.9	25.9	20.6	29.7	24.4	33.4	28.2	41.0	35.7	48.6	43.3	15.7	10.4
VT065S07			9.0	2.8	12.8	16.6	10.4	20.4	14.2	24.1	24.1	18.0	27.9	21.8	31.7	25.5	39.3	33.1	46.8	40.7	18.3	12.2
VT065S08					11.0	14.8	7.8	18.6	11.6	22.4	22.4	15.4	26.2	19.1	30.0	22.9	37.5	30.5	45.1	38.1	21.0	13.9
VT065S09						13.1	5.2	16.9	9.0	20.7	20.7	12.7	24.4	16.5	28.2	20.3	35.8	27.9	43.4	35.4	23.6	15.7
VT065S10							15.1	6.3	18.9	18.9	10.1	22.7	16.9	26.5	17.7	34.0	25.2	41.6	32.8	26.2	17.4	
VT065S11									17.2	17.2	7.5	21.0	11.3	24.7	15.1	32.3	22.6	39.9	30.2	28.8	19.1	
VT065S12												19.2	8.7	23.0	12.4	30.6	20.0	38.1	27.6	31.4	20.9	
VT075S05	16.3	10.2	22.2	16.0	28.1	21.9	34.0	27.8	39.8	33.7	45.7	39.6	51.6	45.4	57.5	51.3	69.2	63.1	81.0	74.8	16.9	10.7
VT075S06	14.2	6.8	20.1	12.7	25.9	18.6	31.8	24.4	37.7	30.3	43.6	36.2	49.4	42.1	55.3	47.9	67.1	59.7	78.8	71.4	20.2	12.8
VT075S07			17.9	9.3	23.8	15.2	29.7	21.1	35.6	29.9	41.4	32.8	47.3	38.7	53.2	44.6	64.9	56.3	76.7	68.1	23.6	15.0
VT075S08					21.7	11.8	27.5	17.7	33.4	23.6	39.3	29.4	45.2	35.3	51.0	41.2	62.8	53.0	74.5	64.7	27.0	17.1
VT075S09						25.4	14.3	31.3	20.2	37.1	26.1	43.0	32.0	48.9	37.8	60.7	49.6	72.4	61.3	30.3	19.3	
VT075S10							29.1	16.8	35.0	22.7	40.9	28.6	46.8	34.5	58.5	46.2	70.3	58.0	33.7	21.4		
VT075S11									32.9	19.3	38.7	25.2	44.6	31.1	56.4	42.8	68.1	55.6	37.1	23.5		
VT075S12												36.6	21.8	42.5	27.7	54.2	39.5	66.0	51.2	40.4	25.7	

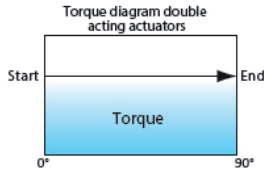
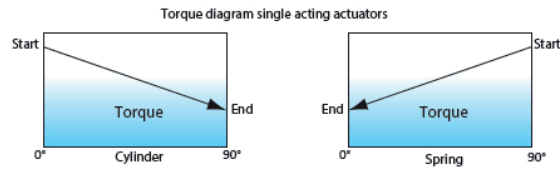
Valores métricos de torque

Rangos de Torque Actuador Simple Efecto en Nm																						
Modelo	Suministro de Presión (Unidad Bar)																				CARRERA DEL RESORTE	
	2.5		3		3.5		4		4.5		5		5.5		6		7		8			
	0°	90°	0°	90°	0°	90°	0°	90°	0°	90°	0°	90°	0°	90°	0°	90°	0°	90°	0°	90°		
VT085S05	23.2	13.7	31.8	22.3	40.4	30.9	49.0	39.5	57.6	48.1	66.3	56.8	74.9	65.4	83.5	74.0	100.8	91.3	118.0	108.5	26.1	16.6
VT085S06	19.8	8.4	28.4	17.0	37.1	25.7	45.7	34.3	54.3	42.9	62.9	51.5	71.6	60.2	80.2	68.8	97.4	86.0	114.7	103.3	31.3	19.9
VT085S07			25.1	11.8	33.8	20.5	42.4	29.1	51.0	37.7	59.6	46.3	68.3	55.0	76.9	63.6	94.1	80.8	111.4	98.1	36.5	23.2
VT085S08					30.4	15.2	39.1	23.9	47.7	32.5	56.3	41.1	64.9	49.7	73.6	58.4	90.8	75.6	108.1	92.1	41.7	26.5
VT085S09							35.8	18.7	44.4	27.3	53.0	35.9	61.6	44.5	70.3	53.2	87.5	70.4	104.8	87.7	46.9	29.8
VT085S10									41.1	22.1	49.7	30.7	58.3	39.3	67.0	48.0	84.2	65.2	101.5	82.5	52.1	33.1
VT085S11											46.4	25.5	55.0	34.1	63.6	42.7	80.9	60.0	98.1	77.2	57.3	36.4
VT085S12													51.7	28.9	60.3	37.5	77.6	54.8	94.8	72.0	62.5	39.7
VT095S05	33.6	209	45.8	33.0	57.9	45.1	70.0	57.3	82.1	69.4	94.3	81.8	106.4	93.6	118.5	105.8	142.7	130.0	167.0	154.2	34.9	22.1
VT095S06	29.2	13.9	41.4	26.1	53.5	38.2	65.6	50.3	77.7	62.4	89.8	74.5	102.0	86.7	114.1	98.8	138.3	123.0	162.6	147.3	41.8	26.5
VT095S07			36.9	19.1	49.1	31.2	61.2	43.3	73.3	55.4	85.4	67.6	97.5	79.7	109.7	91.8	133.9	116.1	158.1	140.3	48.8	30.9
VT095S08					44.6	24.2	56.8	36.4	68.9	48.5	81.0	60.6	93.1	72.7	105.2	84.8	129.5	109.1	153.7	133.3	55.8	35.4
VT095S09							52.3	29.4	64.5	41.5	76.6	53.6	88.7	65.8	100.8	77.9	125.1	102.1	149.3	126.4	62.7	39.8
VT095S10									60.0	34.5	72.2	46.7	84.3	58.8	96.4	70.9	120.6	95.1	144.9	119.4	69.7	44.2
VT095S11											67.7	39.7	79.9	51.8	92.0	63.9	116.2	88.2	140.5	112.4	76.7	48.6
VT095S12													75.4	44.8	87.6	57.0	111.8	81.2	136.0	105.4	83.6	53.0
VT110S05	43.4	26.2	60.7	43.3	76.4	59.1	92.0	74.8	107.7	90.4	123.4	106.1	139.0	121.8	154.7	137.4	186.0	168.8	217.3	200.1	45.9	28.6
VT110S06	37.7	17.0	55.0	34.3	70.6	49.9	86.3	65.6	102.0	81.3	117.6	96.9	133.3	112.6	149.0	128.3	180.3	159.6	211.6	190.9	55.0	34.3
VT110S07			49.3	25.1	64.9	40.8	80.6	56.4	96.2	72.1	111.9	87.8	127.6	103.4	143.2	119.1	174.6	150.4	205.9	181.8	64.2	40.0
VT110S08					59.2	31.6	74.9	47.3	90.5	62.9	106.2	78.6	121.9	94.3	137.5	109.9	168.9	141.3	200.2	172.6	73.4	45.8
VT110S09							69.1	38.1	84.8	53.8	100.5	69.4	116.1	85.1	131.8	100.8	163.1	132.1	194.0	163.4	82.0	51.5
VT110S10									79.1	44.6	94.8	60.3	110.4	75.9	126.1	91.6	157.4	122.9	188.7	154.2	91.7	57.2
VT110S11											89.0	51.1	104.7	66.7	120.4	82.4	151.7	113.7	183.0	145.1	100.9	62.9
VT110S12													99.0	57.6	114.6	73.2	146.0	104.6	177.3	135.9	110.0	68.6
VT125S05	77.7	48.2	108.5	78.9	136.5	106.9	164.4	134.9	192.4	162.9	220.4	190.9	248.4	218.8	276.4	246.8	332.3	302.8	388.3	358.7	80.6	51.0
VT125S06	67.5	32.0	98.3	62.8	126.3	90.8	154.2	118.8	182.2	146.8	210.2	174.7	238.2	202.7	266.2	230.7	322.1	286.7	378.1	342.6	96.7	61.2
VT125S07			88.1	46.7	116.1	74.7	144.0	102.7	172.0	130.7	200.0	158.6	228.0	186.6	256.0	214.6	311.9	270.6	367.9	326.5	112.8	71.4
VT125S08					105.9	58.6	133.8	86.6	161.8	115.5	198.8	142.5	217.8	170.5	245.8	198.5	301.7	254.4	357.7	310.4	128.9	81.6
VT125S09							123.6	70.5	151.6	98.4	179.6	126.4	207.6	154.4	235.6	182.4	297.5	238.3	347.5	294.3	145.8	91.8
VT125S10									141.4	82.3	169.4	110.3	197.4	138.3	225.4	166.3	281.3	222.2	337.3	278.2	161.1	102.0
VT125S11											159.2	94.2	187.2	122.2	215.2	150.2	271.1	206.1	327.1	262.1	177.2	112.2
VT125S12													177.0	106.1	205.0	134.0	260.9	190.0	316.9	246.0	193.3	122.4
VT140S05	114.2	74.1	155.1	115	196.1	156	237.0	196.4	277.9	237.8	318.8	278.7									122.4	82.3
VT140S06	97.7	49.6	138.7	90.6	179.6	131.5	220.5	172.4	261.5	213.3	302.4	254.3	343.3	295.2							146.8	98.7
VT140S07			122.2	66.1	163.2	107.0	204.1	147.9	245.0	188.9	285.9	229.8	326.9	270.7	367.8	311.6					171.3	115.2
VT140S08					146.7	82.5	187.6	123.5	228.6	164.4	269.5	205.3	310.4	246.2	351.3	287.2	433.2	369.0			195.8	131.6
VT140S09							171.2	99.0	212.1	139.9	253.0	180.9	294.0	221.8	334.9	262.7	416.7	344.6	498.6	426.4	220.2	148.1
VT140S10									195.7	115.5	236.6	156.4	277.5	197.3	318.4	238.2	400.3	320.1	482.1	401.9	244.7	164.5
VT140S11											220.1	131.9	261.1	172.8	302.0	213.8	383.8	295.6	465.7	377.5	269.2	181.0
VT140S12													244.6	148.4	285.5	189.3	367.4	271.1	449.2	353.0	293.3	197.4
VT160S05	153.5	101.3	216.6	164.4	273.9	221.7	331.2	279.0	388.5	336.3	445.8	393.6	503.1	450.9	560.4	508.2	675.0	622.8	789.7	737.4	162.3	110.0
VT160S06	131.5	68.8	194.6	131.9	251.9	189.2	309.2	246.5	366.5	303.8	443.8	361.1	481.1	418.4	538.4	475.7	653.0	590.3	767.7	705.0	194.7	132.0
VT160S07			172.6	99.5	229.9	156.8	287.2	214.1	344.5	271.4	401.8	328.7	459.1	386.0	516.4	443.3	631.0	557.9	745.7	672.5	227.2	154.0
VT160S08					207.9	124.3	265.2	181.6	322.5	238.9	379.8	296.2	437.1	353.5	494.4	410.8	609.0	525.4	723.7	640.1	259.6	176.0
VT160S09							243.2	149.2	300.5	206.5	357.8	263.8	415.1	321.1	472.4	378.4	587.0	493.0	701.7	607.6	292.1	198.0
VT160S10									278.5	174.0	335.8	231.3	393.1	288.6	450.4	345.9	565.0	460.5	679.7	575.2	324.5	220.0
VT160S11											313.8	198.9	371.1	256.2	428.4	313.5	543.0	428.1	657.7	542.7	357.0	242.0
VT160S12													349.1	223.7	406.4	281.0	521.0	395.6	635.7	510.3	389.4	264.0
VT190S05	246.8	167.4	336.3	256.9	425.6	346.2	514.9	435.5	604.2	524.8	693.5	614.1									261.2	181.8
VT190S06	210.4	115.1	299.9	204.6	389.2	293.9	478.5	383.3	657.8	472.6	657.2	561.9	746.5	651.2							313.4	218.1
VT190S07			263.6	152.4	352.9	241.7	442.2	331.0	531.5	420.3	620.8	509.6	710.1	599.0	799.4	688.3					365.6	254.5
VT190S08					316.5	189.5	405.8	278.7	495.1	368.1	584.5	457.4	763.8	546.7	779.5	636.0	941.7	814.7			417.8	290.8
VT190S09							369.5	226.6	458.8	315.9	548.1	405.2	637.4	494.5	745.2	583.8	905.3	726.4	1084.0	941.1	470.1	327.2
VT190S10									422.4	263.6	511.8	353.0	601.1	423.3	710.9	531.6	869.0	710.2	1047.6	888.8	522.3	363.5
VT190S11											475.4	300.7	564.7	390.0	676.6	479.3	832.6	658.0	1011.3	836.6	574.5	399.9
VT190S12													528.4	337.8	642.3	427.1	796.3	605.7	974.9	784.4	628.8	436.8

Valores métricos de torque

Rangos de Torque Actuador Simple Efecto en Nm																						
Modelo	Suministro de Presión (Unidad Bar)																					
	2.5		3		3.5		4		4.5		5		5.5		6		7		8		CARRERA DEL RESORTE	
	0°	90°	0°	90°	0°	90°	0°	90°	0°	90°	0°	90°	0°	90°	0°	90°	0°	90°	0°	90°	90°	0°
VT210S05	352.8	239.1	477.8	364.1	602.5	488.8	727.2	613.5	851.9	738.2	976.6	862.9	1101.2	987.5	1225.9	1112.2	1475.3	1361.6	1724.7	1611.0	359.1	245.4
VT210S06	303.7	167.3	428.7	292.3	553.4	417.0	678.1	541.7	802.8	666.4	927.5	791.0	1052.2	915.7	1176.9	1040.4	1426.2	1289.8	1675.6	1539.2	430.9	294.5
VT210S07			379.6	220.5	504.3	345.2	629.0	469.8	753.7	594.5	878.4	719.2	1003.1	843.9	1127.8	968.6	1377.2	1218.0	1626.5	1467.4	502.7	343.6
VT210S08					455.3	273.3	579.9	398.0	704.6	522.7	829.3	647.4	954.0	772.1	1078.7	896.8	1328.1	1146.2	1577.5	1395.5	574.6	392.6
VT210S09							530.9	326.2	655.6	450.9	780.2	575.6	904.9	700.3	1029.6	825.0	1279.0	1074.3	1528.4	1323.7	646.4	441.7
VT210S10									606.5	379.1	731.2	503.8	855.8	628.4	980.5	753.1	1229.9	1002.5	1479.3	1251.9	718.2	490.8
VT210S11											682.1	431.9	806.8	556.6	931.5	681.3	1180.8	930.7	1430.2	1180.1	790.0	539.9
VT210S12													757.7	484.8	882.4	609.5	1131.8	858.9	1381.1	1108.3	861.8	589.0
VT240S05	517.8	374.3	711.2	567.7	904.6	761.1	1098.0	954.5	1291.4	1147.9	1484.8	1341.3									554.0	410.5
VT240S06	435.7	263.5	629.1	456.9	822.5	650.3	1015.9	843.7	1209.3	1037.1	1402.7	1230.5	1596.1	1423.9							664.8	492.6
VT240S07			547.0	346.1	740.4	539.5	933.8	732.9	1127.2	926.3	1320.6	1119.7	1514.0	1313.1	1707.4	1506.5					775.6	574.7
VT240S08					658.3	428.7	851.7	622.1	1045.1	815.5	1238.5	1008.9	1431.9	1202.3	1625.3	1395.7	2012.1	1782.5			886.4	656.8
VT240S09							769.6	511.3	963.0	704.7	1156.4	898.1	1349.8	1091.5	1543.2	1284.9	1930.0	1671.7	2316.8	2058.5	997.2	738.9
VT240S10									880.9	593.9	1074.3	787.3	1267.7	980.7	1461.1	1174.1	1847.9	1590.9	2234.7	1947.7	1108.0	821.0
VT240S11											992.3	676.5	1185.6	869.9	1379.0	1063.3	1765.8	1450.1	2152.6	1836.9	1218.8	903.1
VT240S12													1103.5	759.1	1296.9	952.5	1683.7	1339.3	2070.5	1726.1	1329.6	952.2
VT270S05	745.9	519.4	1017.9	791.4	1289.9	1063.4	1561.8	1335.3	1833.8	1607.3	2108.7	1879.2									786.0	559.5
VT270S06	634.0	362.2	906.0	634.2	1178.0	906.2	1449.9	1178.1	1721.9	1450.1	1993.8	1722.0	2265.8	1994.0							943.2	671.4
VT270S07			974.1	477.0	1166.1	749.0	1338.0	1020.9	1610.0	1292.9	1881.9	1564.8	2153.9	1836.8	2425.9	2108.8					1100.4	783.3
VT270S08					954.2	591.8	1226.1	863.7	1498.1	1135.7	1770.0	1407.6	2042.0	1679.6	2314.0	1951.6	2857.9	2495.5			1257.6	895.2
VT270S09							1114.2	706.5	1386.2	978.5	1658.1	1250.4	1930.1	1522.4	2202.1	1794.4	2746.0	2338.3	3289.9	2882.2	1414.8	1007.1
VT270S10									1274.3	821.3	1546.2	1093.2	1818.2	1365.2	2090.2	1637.2	2634.1	2881.1	3178.9	2725.0	1572.0	1119.0
VT270S11											1434.3	936.0	1706.3	1208.0	1978.3	1480.0	2522.2	2023.9	3066.1	2567.8	1729.2	1230.9
VT270S12													1594.4	1050.8	1866.4	1322.8	2410.3	1866.7	2954.2	2410.6	1886.4	1342.8
VT300S05	987.5	646.7	1338.3	997.5	1688.2	1347.4	2038.1	1697.3	2388.0	2047.2	2737.9	2397.1	3087.8	2747.0	3437.7	3096.9	4137.4	3796.6	4837.2	4496.4	1031.9	691.1
VT300S06	849.3	440.3	1200.1	791.1	1550.0	1141.0	1899.9	1490.9	2249.8	1840.8	2599.6	2190.7	2949.5	2540.6	3299.4	2890.5	3999.2	3590.3	4699.0	4290.1	1238.3	829.3
VT300S07			1061.9	584.7	1411.7	934.6	1761.6	1284.5	2111.5	1634.4	2461.4	1984.3	2811.3	2334.2	3161.2	2684.1	3861.0	3383.9	4560.8	4083.7	1444.7	967.5
VT300S08					1273.5	728.2	1623.4	1078.1	1973.3	1428.0	2323.2	1777.9	2673.1	2127.8	3023.0	2477.7	3722.8	3177.5	4422.6	3877.3	1651.0	1105.8
VT300S09							1485.2	871.8	1835.1	1221.7	2185.0	1571.5	2534.9	1921.4	2884.8	2271.3	3584.6	2971.1	4284.4	3670.9	1857.4	1244.0
VT300S10									1696.9	1015.3	2046.0	1365.2	2396.7	1715.1	2746.6	2065.0	3446.3	2764.7	4146.1	3464.5	2063.8	1382.2
VT300S11											1908.5	1158.8	2258.4	1508.7	2608.3	1858.6	3308.1	2558.4	4007.9	3258.2	2270.2	1520.4
VT300S12													2120.2	1302.3	2470.1	1652.2	3169.9	2352.0	3869.7	3051.8	2476.6	1658.6
VT350S05	1498.2	1017.1	2017.5	1536.4	2536.8	2055.6	3056.1	2574.9	3575.3	3094.2	4094.6	3613.5	4613.9	4132.7	5133.2	4652.0	6171.7	5690.6	7210.3	6729.1	1475.5	994.3
VT350S06			1818.6	1241.3	2337.9	1760.5	2857.2	2279.8	3376.5	2799.1	3895.8	3318.4	4415.0	3837.7	4934.3	4356.9	5972.9	5395.5	7011.4	6434.0	1770.5	1193.2
VT350S07			1619.8	946.2	2139.1	1465.5	2658.3	1984.7	3177.6	2504.0	3996.9	3023.3	4216.2	3542.6	4735.5	4061.8	5774.0	5100.4	6812.6	6139.0	2065.6	1392.0
VT350S08					1940.2	1170.4	2459.5	1689.6	2978.8	2208.9	3498.0	2728.2	4017.3	3247.5	4536.6	3766.8	5575.1	4805.3	6613.7	5843.9	2360.7	1590.9
VT350S09					1741.3	875.3	2260.6	1394.6	2779.9	1913.8	3299.2	2433.1	3818.5	2952.4	4337.7	3471.7	5376.3	4510.2	6414.8	5548.8	2655.8	1789.7
VT350S10							2061.8	1099.5	2581.0	1618.7	3100.3	2138.0	3619.6	2657.3	4138.9	3176.6	5177.4	4215.1	6216.0	5253.7	2950.9	1988.6
VT350S11							1862.9	804.4	2382.2	1323.7	2901.5	1842.9	3420.7	2362.2	3940.0	2881.5	4978.6	3920.0	6017.1	4958.6	3246.0	2187.5
VT350S12									2183.3	1028.6	2702.6	1547.8	3221.9	2067.1	3741.2	2586.4	4779.7	3624.9	5818.3	4663.5	3541.1	2386.3
VT400S05	2222.0	1497.0	3013.0	2288.0	3805.0	3080.0	4596.0	3871.0	5387.0	4662.0	6179.0	5454.0									2310.0	576.0
VT400S06			2698.0	1828.0	3490.0	2620.0	4281.0	3411.0	5072.0	4202.0	5863.0	4933.0	6655.0	5785.0							2761.0	1891.0
VT400S07				1368.0	3174.0	2195.0	3966.0	2951.0	4757.0	3742.0	5548.0	4533.0	6339.0	5324.0	7131.0	6116.0					3221.0	2206.0
VT400S08					2859.0	1699.0	3650.0	2490.0	4442.0	3282.0	5233.0	4073.0	6024.0	4864.0	6816.0	5656.0	8398.0	7238.0			3682.0	2522.0
VT400S09					2544.0	1239.0	3335.0	2030.0	4126.0	2821.0	4918.0	3613.0	5709.0	4404.0	6500.0	5195.0	8083.0	6778.0	9665.0	8360.0	4142.0	2837.0
VT400S10							3020.0	1570.0	3811.0	2361.0	4603.0	3153.0	5394.0	3944.0	6185.0	4735.0	7768.0	6318.0	9350.0	7900.0	4602.0	3152.0
VT400S11							2705.0	1110.0	3496.0	1901.0	4287.0	2692.0	5079.0	3484.0	5870.0	4275.0	7452.0	5857.0	9035.0	7440.0	5062.0	3467.0
VT400S12									3181.0	1441.0	3972.0	2232.0	4763.0	2023.0	5555.0	3815.0	7137.0	5397.0	8720.0	6980.0	5522.0	3782.0

Vistas y normas de montaje

Vista Frontal

Vista Lateral

Vista Superior

Vista Inferior

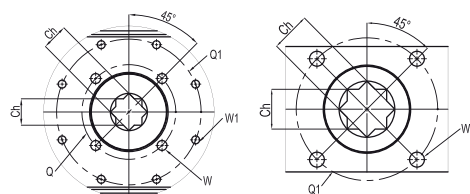
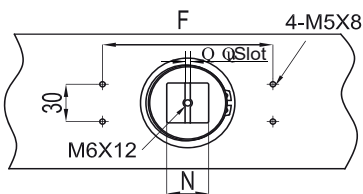
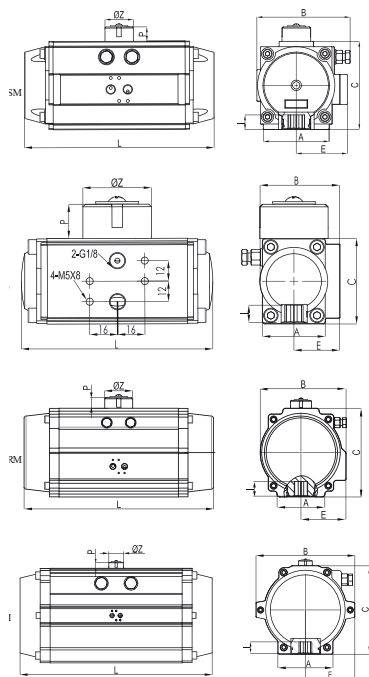

Conexión de Aire

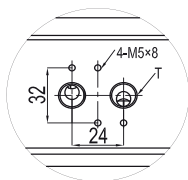

G1/4 NAMUR
VT50-V T210

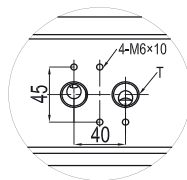

G1/2 NAMUR
T240- T400

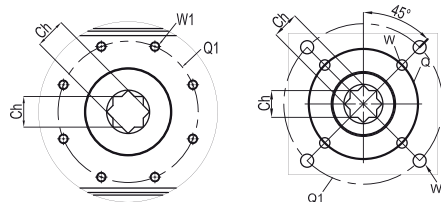

Modelo	A	B	C	L	E	F	P	ø Z	N	I	Brida	Q	Q1	W	W1	Ch	T
VT032	37	47	50	110	27	50	20	40	10	10	F03	-	36	-	M5X9	9X9	G1/8"
VT050	45	70.5	70	154	41.5	80	20	40	10	12	F03/05	36	50	M5X7.5	M6X9	11X11	G1/4"
VT065	62	89.5	89	189	51.5	80	20	40	10	16	F05/07	50	70	M6X9	M8X12	14X14	G1/4"
VT075	68	102.5	100	210	59	80	20	40	14	16	F05/07	50	70	M6X9	M8X12	14X14	G1/4"
VT085	68	112.5	113	229	63.5	80	20	40	14	19	F05/07	50	70	M6X9	M8X12	17X17	G1/4"
VT095	92	126	123	264	71	80	20	40	14	19	F05/07	70	102	M6X9	M8X12	17X17	G1/4"
VT110	93	138.5	136	266	76.5	80	20	40	14	19	F07/10	70	102	M8X12	M10X15	17X17	G1/4"
VT125	96	157	161	337	85	80	30	56	22	25	F07/10	70	102	M8X12	M10X15	22X22	G1/4"
VT140	110	178	178	377	97	80	30	56	22	31	F10/12	102	125	M10X15	M12X18	27X27	G1/4"
VT160	112	196	200	412	106	130	30	56	22	31	F10/12	102	125	M10X15	M12X18	27X27	G1/4"
VT190	136	216.5	232	488	112	130	30	56	22	41	F10/14	102	140	M10X15	M16X24	36X36	G1/4"
VT210	140	235.5	255	550	120	130	30	80	32	40	F14	-	140	-	M16X24	36X36	G1/4"
VT240	159	262	292	602	131	130	30	80	32	50	F16	-	165	-	M20X28	46X46	G1/2"
VT270	159	295	331	672	147.5	130	30	80	32	50	F16	-	165	-	M20X28	46X46	G1/2"
VT300	180	335	354	784	173	130	30	80	32	50	F16	-	165	-	M20X28	46X46	G1/2"
VT350	270	385	410	845	195	130	30	80	32	50	F16/25	165	254	M20X28	M16X30	46X46	G1/2"
VT400	290	520	466	956	260	130	30	80	32	60	F25	-	254	-	M16X30	55X55	G1/2"